



31015 INSTALLATION INSTRUCTIONS



Safety glasses should be worn at all times while installing this product.

YEARS: 2010-CURRENT

MAKE: DODGE RAM

MODEL: 2500

STYLE: TRUCK

WARNING: NEVER EXCEED YOUR VEHICLE MANUFACTURER'S RECOMMENDED TOWING CAPACITY

WEIGHT CARRYING:
TRAILER WEIGHT: 5,000 LBS.
TONGUE WEIGHT: 500 LBS.

GROSS LOAD CAPACITY WHEN USED AS A STRAIGHT LINE PULL:
9,000 LBS MAX.

INSTALLATION TIME: 30 MIN.
THE INSTALL TIME LISTED IS FOR PROFESSIONAL INSTALLERS. IF YOU ARE HESITANT TO UNDERTAKE THIS TASK ON YOUR OWN, CONTACT AN AUTHORIZED CURT INSTALLER FOR ADDITIONAL ASSISTANCE.

- INSTALLATION TIPS:**
- BEFORE YOU BEGIN INSTALLATION, READ ALL INSTRUCTIONS THOROUGHLY.
 - TO EASE INSTALLATION, 2 PEOPLE MAY BE REQUIRED.
 - USING PROPER TOOLS WILL GREATLY IMPROVE THE QUALITY OF THE INSTALL AND REDUCE THE TIME REQUIRED.
 - NEED HELP OR HAVE SOME QUESTIONS? CALL TECHNICAL SUPPORT AT 800.798.0813



INSTALLATION REQUIRES:

| | | |
|---------------|----------------|-----------------|
| | | |
| RATCHET | SOCKET | AVIATION SHEARS |
| | | |
| TORQUE WRENCH | SAFETY GLASSES | |
| | | |
| | | |

LEVEL OF DIFFICULTY: MODERATE

| EASY | MODERATE | HARD |
|------|--------------------------|------|
| | FISHWIRE HARDWARE | |
| | NO DRILLING REQUIRED | |
| | FASCIA TRIMMING REQUIRED | |
| | | |
| | | |

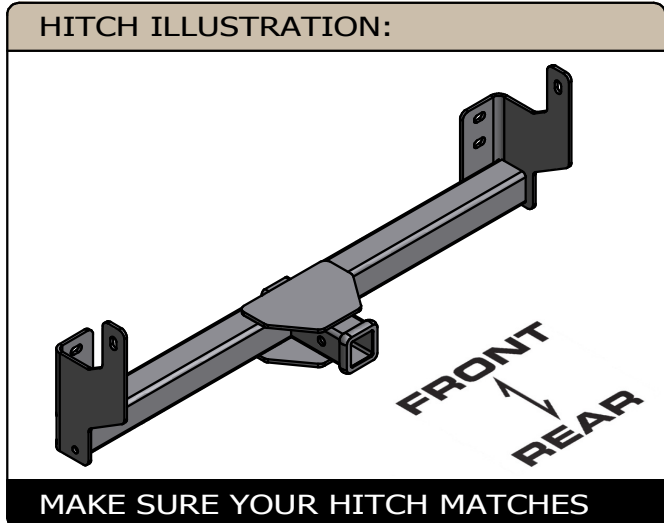

PERIODICALLY CHECK THIS RECEIVER HITCH TO ENSURE ALL FASTENERS ARE TIGHT AND ALL STRUCTURAL COMPONENTS ARE SOUND

CURT Manufacturing Inc. warrants this product to be free of defects in material and/or workmanship at the time of retail purchase by the original purchaser. If the product is found to be defective, Curt Manufacturing Inc. may repair or replace the product at their option, when the product is returned, prepaid, with proof of purchase. Alteration to, misuse of, or improper installation of this product voids the warranty. Curt Manufacturing Inc.'s liability is limited to repair or replacement of products found to be defective, and specifically excludes liability for incidental or consequential loss or damage.

For more information log onto www.curtmfg.com, & for helpful towing tips log onto www.hitchinfo.com

INSTALLATION WALKTHROUGH:

| Parts List | | | | |
|------------|-----|-----------------|--|--|
| ITEM | QTY | PART NUMBER | DESCRIPTION | |
| 1 | 4 | 7/16-14 x 1 1/4 | CARRIAGE BOLT | |
| 2 | 4 | CM-SP2 | .250 x .88 x 2.25" SQUARE HOLE SPACER | |
| 3 | 4 | 7/16-14 | LARGE HEX FLANGE NUT | |
| 4 | 2 | M12-1.75 | HEX FLANGE NUT | |
| 5 | 2 | CM-SP43 | .375 x 1.25 x 2.50" SQUARE HOLE SPACER | |
| 6 | 2 | 7_16 FISHWIRE | 7/16" FISHWIRE | |

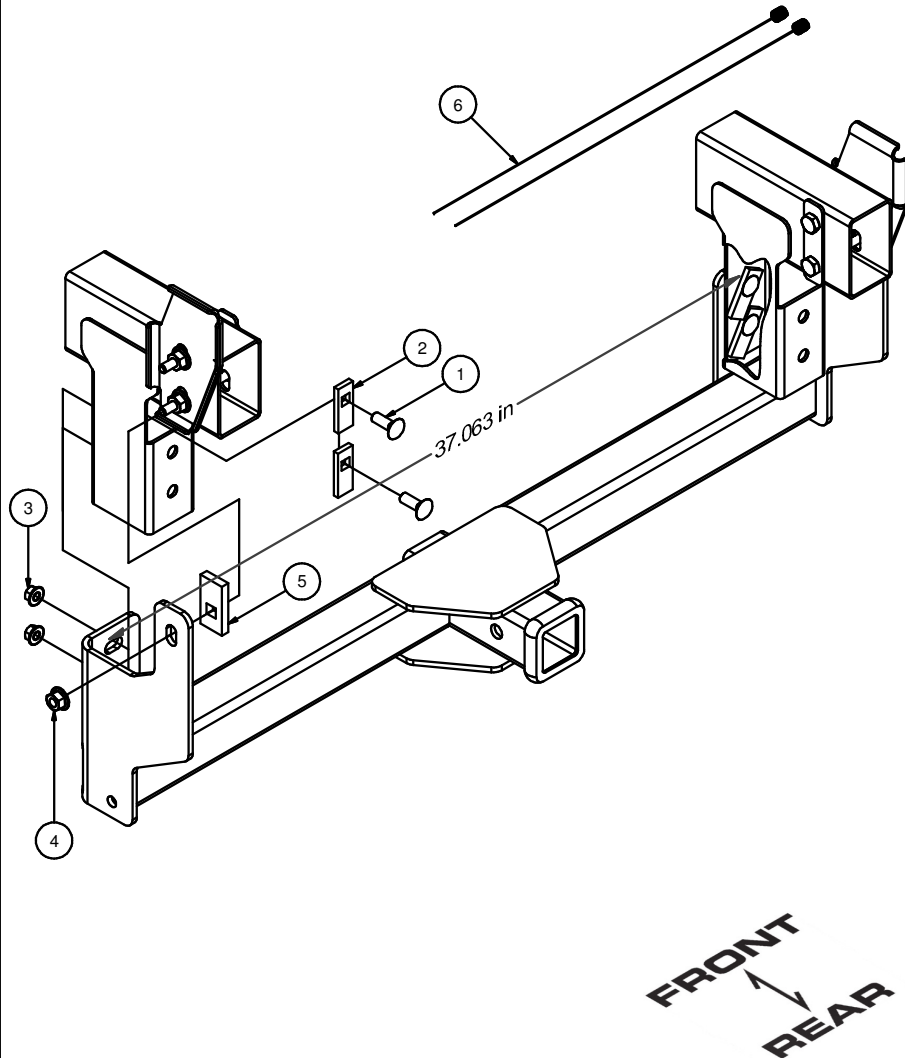

1. Find center of vehicle and trim front bumper fascia (SEE FRONT BUMPER TRIM DIAGRAM BELOW).



FRONT BUMPER TRIM DIAGRAM

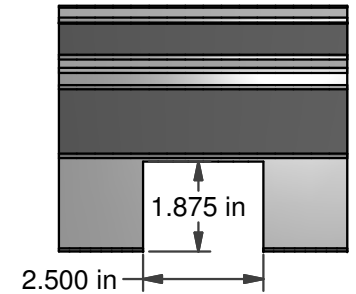

2. Remove (2) nuts that secure the bumper bolts. These are located near front of vehicle on outside of the frame rail on each side. Top nut will be reinstalled and bottom nut will be replaced with the included M12-1.75 hex flange nut on each side.

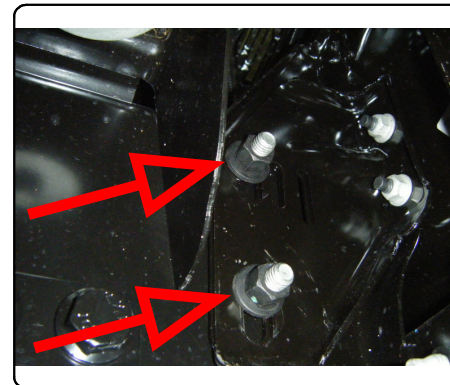

INSTALLATION WALKTHROUGH:

3. Put CM-SP43 spacer on bottom bolt. Push bolts in so they are flush with the spacer. Repeat on other side.

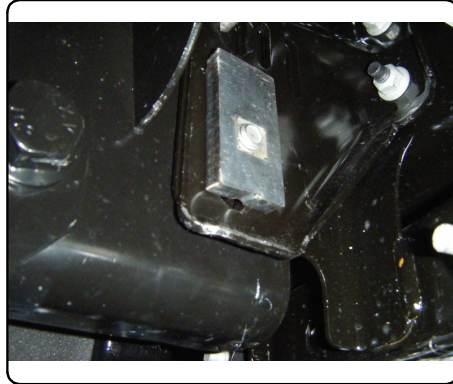

4. Raise hitch into position and push bolts out. Attach M12-1.75 hex flange nut to bottom bolt on each side. Re-attach (2) nuts removed in STEP 2 to top bolt on each side.

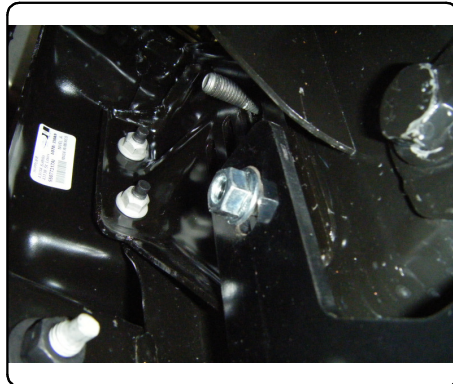

5. Fishwire 7/16 in. bolts and spacers into position and secure with nuts as shown.

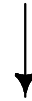
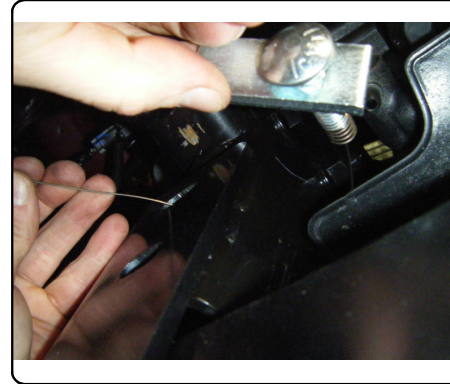

6. Torque all M12 hardware to 79 ft-lbs and 7/16 in hardware to 70 ft-lbs.
Install is complete.

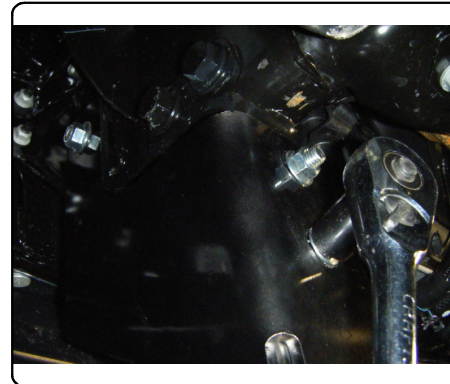

31015**2010-CURRENT DODGE RAM 2500**

10/5/2012

GROSS LOAD CAPACITY WHEN USED AS A WEIGHT CARRYING HITCH: 5,000 LBS. TRAILER WEIGHT & 500 LBS. TONGUE WEIGHT.

GROSS LOAD CAPACITY WHEN USED AS A STRAIGHT LINE PULL: 9,000 LBS. MAX. LINE PULL.

***** DO NOT EXCEED VEHICLE MANUFACTURER'S RECOMMENDED TOWING CAPACITY. *****

HAVING INSTALLATION QUESTIONS? CALL TECHNICAL SUPPORT AT 1-800-798-0813

| Parts List | | | | |
|------------|-----|-----------------|--|--|
| ITEM | QTY | PART NUMBER | DESCRIPTION | |
| 1 | 4 | 7/16-14 x 1 1/4 | CARRIAGE BOLT | |
| 2 | 4 | CM-SP2 | .250 x .88 x 2.25" SQUARE HOLE SPACER | |
| 3 | 4 | 7/16-14 | LARGE HEX FLANGE NUT | |
| 4 | 2 | CM-SP43 | .375 x 1.25 x 2.50" SQUARE HOLE SPACER | |
| 5 | 2 | M12-1.75 | HEX FLANGE NUT | |
| 6 | 2 | 7_16 FISHWIRE | 7/16" FISHWIRE | |

| TOOLS REQUIRED |
|---------------------|
| RATCHET |
| 11/16", 18mm SOCKET |
| TORQUE WRENCH |
| AVIATION SHEARS |
| TAPE MEASURE |

FRONT
↑
REAR

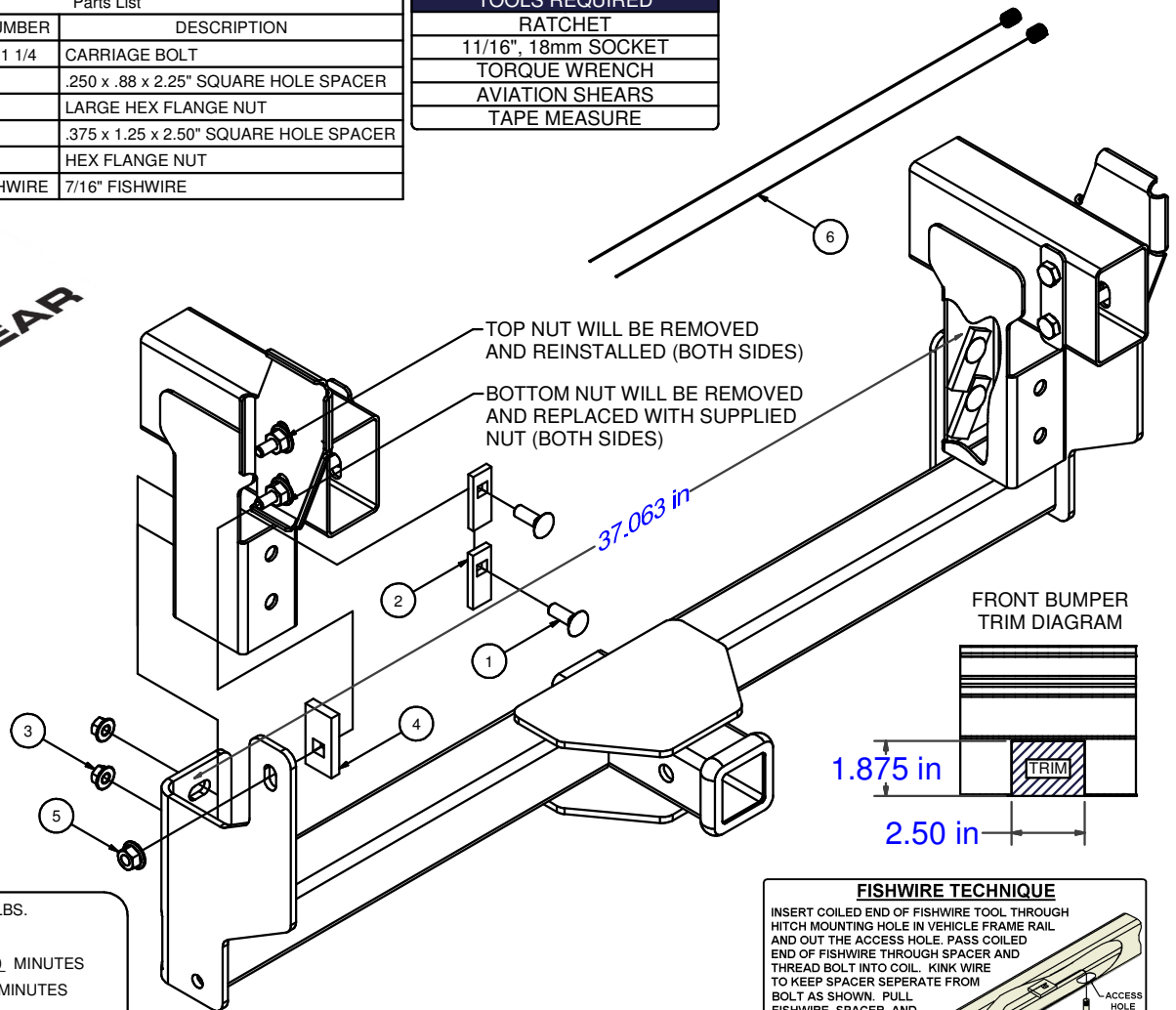

HITCH WEIGHT: .39 LBS.

INSTALL TIME

PROFESSIONAL: 30 MINUTES

NOVICE (DIY): 60 MINUTES

INSTALL NOTES:

- NO DRILLING REQUIRED
- FASCIA TRIMMING REQUIRED

FISHWIRE TECHNIQUE

INSERT COILED END OF FISHWIRE TOOL THROUGH HITCH MOUNTING HOLE IN VEHICLE FRAME RAIL AND OUT THE ACCESS HOLE. PASS COILED END OF FISHWIRE THROUGH SPACER AND THREAD BOLT INTO COIL. KINK WIRE TO KEEP SPACER SEPARATE FROM BOLT AS SHOWN. PULL FISHWIRE, SPACER, AND BOLT THROUGH FRAME AND OUT MOUNTING HOLE. USE FISHWIRE TO GUIDE HITCH DURING MOUNTING AND PREVENT LOSS OF BOLT / SPACER INSIDE FRAME RAIL.

NOTE: SOME VEHICLES MAY FISHWIRE THROUGH END OF FRAME

INSTALLATION STEPS

1. Find center of vehicle and trim front bumper fascia (SEE FRONT BUMPER TRIM DIAGRAM ABOVE).
2. Remove (4) nuts (AS SHOWN ABOVE). Top nut will be reinstalled and bottom nut will be replaced with the included M12-1.75 hex flange nut on each side.
3. Put CM-SP43 spacer on bottom bolt. Push bolts in so they are flush with the spacer. Repeat on other side.
4. Raise hitch into position, push bolts out and attach M12-1.75 hex flange nuts to bottom bolt on each side.
5. Reattach (2) nuts removed in STEP 2 to top bolt on each side.
6. Fishwire bolts and spacers into position and secure with nuts as shown.
7. Torque all M12 hardware to 79 ft-lbs and 7/16 in hardware to 70 ft-lbs.

PERIODICALLY CHECK THIS RECEIVER HITCH TO ENSURE THAT ALL FASTENERS ARE TIGHT AND THAT ALL STRUCTURAL COMPONENTS ARE SOUND.

Curt Manufacturing Inc., warrants this product to be free of defects in material and/or workmanship at the time of retail purchase by the original purchaser. If the product is found to be defective, Curt Manufacturing Inc., may repair or replace the product, at their option, when the product is returned, prepaid, with proof of purchase. Alteration to, misuse of, or improper installation of this product voids the warranty. Curt Manufacturing Inc.'s liability is limited to repair or replacement of products found to be defective, and specifically excludes liability for incidental or consequential loss or damage.

*****DO NOT EXCEED VEHICLE MANUFACTURER'S RECOMMENDED TOWING CAPACITY*****.

FRONT MOUNTED ACCESSORIES

1) Do not exceed front axle Gross Weight Rating (GAWR). Consult owners manual or specification plate located on driver's door frame. Measure gross front axle weight by placing front wheels of loaded vehicle on a scale.

WARNING: Exceeding GAWR may overload the front axle and/or suspension. This could result in **accident, property damage and personal injury.**

- 2) Reposition front mounted license plate if obstructed.
- 3) Do not obstruct vehicle lights.
- 4) Allow free air flow into grille opening.
- 5) Rear wheel traction may be reduced. This could effect handling. Reduce speed and drive with caution.
- 6) Accessories extend front of vehicle. This may reduce approach angle. Use caution when parking and maneuvering.
- 7) Do not obstruct driver view.

VEHICLE RECOVERY AND WINCHING TIPS

1) Use OEM tow hooks, recovery eyes or a clevis mount for attachment of a tow strap or winch cable.

WARNING: NEVER use a ball and/or ball mount as an anchor point for tow strap or winch cable. Severe personal injury or death could result.

- 2) Observe winch manufacturer's recommendations, cautions and warnings.
- 3) Attach return cable to tow hook or recovery eye when using a snatch block (See figure 1).

CAUTION: Do not attach return cable to winch mount. This may overload winch mount and/or front mounted receiver.

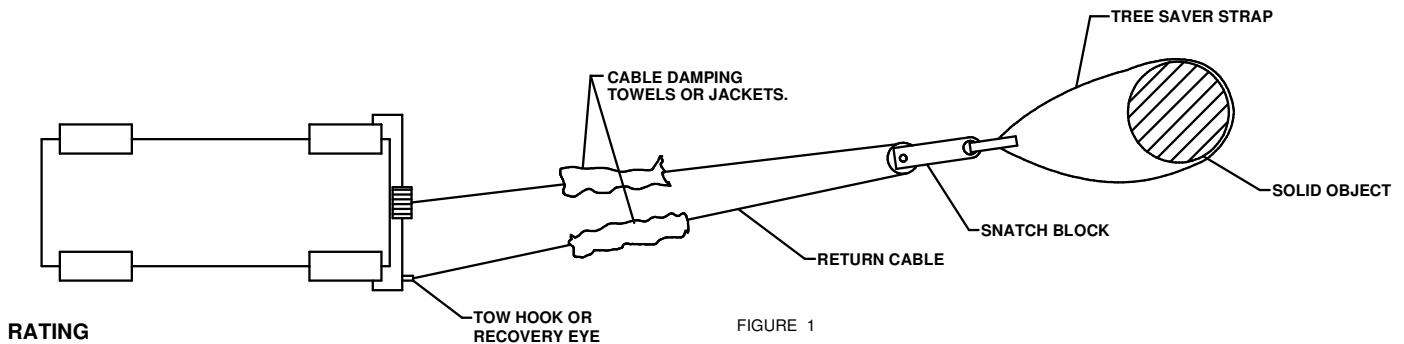

RATING

For **Maximum** line pull rating, winch cable must not exceed:

- 15 degree angle up or down from horizontal (See Figure 2).
- 45 degree angle left or right from straight ahead (See Figure 3).

CAUTION: Exceeding the maximum line pull rating may over load winch, winch mount, and/or front mounted receiver.

