

# RideCONTROL

by AIR LIFT®

## Kit 59569

### *Ford Transit Connect rear application*



## INSTALLATION GUIDE

For maximum effectiveness and safety, please read these instructions completely before proceeding with installation.

*Failure to read these instructions can result in an incorrect installation.*



# TABLE OF CONTENTS

<b>Introduction</b> .....	<b>2</b>
Important Safety Notice .....	2
Notation Explanation .....	2
<b>Installation Diagram</b> .....	<b>3</b>
Hardware List .....	3
Tools List .....	3
<b>Assembling the Air Spring Assembly</b> .....	<b>4</b>
<b>Installing the RideControl System</b> .....	<b>6</b>
Getting Started .....	6
Installing the Air Lines .....	8
Checking for Leaks .....	10
Fixing Leaks .....	10
<b>Before Operating</b> .....	<b>11</b>
Installation Checklist .....	11
Post-installation checklist .....	11
<b>Product Use, Maintenance and Servicing</b> .....	<b>11</b>
Minimum Air Pressure and Maximum Air Pressure .....	11
Maintenance Guidelines .....	12
Troubleshooting Guide .....	12
Frequently Asked Questions .....	12
Tuning the Air Pressure .....	13
Guidelines for Adding Air .....	13
<b>Warranty and Returns Policy</b> .....	<b>14</b>
<b>Replacement Parts and Returns</b> .....	<b>15</b>
<b>Replacement Information</b> .....	<b>15</b>
<b>Contact Information</b> .....	<b>16</b>

# Introduction

The purpose of this publication is to assist with the installation, maintenance and troubleshooting of the RideControl air spring kit. The air springs used in RideControl kits are designed and manufactured like a tire. The air springs have layers of rubber and cords that control the bag's growth and funnel it into one direction. The bags do not require a coil spring for control. RideControl kits utilize a sleeve style air bag that provides up to 2,000 pounds of load-leveling support. Each sleeve is rated at a maximum of 100 PSI.

It is important to read and understand the entire installation guide before beginning installation or performing any maintenance, service or repair. The information here includes a hardware list, tool list, step-by-step installation information, maintenance guidelines and operating tips.

Air Lift Company reserves the right to make changes and improvements to its products and publications at any time. For the latest version of this manual, contact Air Lift Company at (800) 248-0892 or visit our website at [www.airliftcompany.com](http://www.airliftcompany.com).

## IMPORTANT SAFETY NOTICE

The installation of this kit does not alter the Gross Vehicle Weight Rating (GVWR) or payload of the vehicle. Check your vehicle's owner's manual and do not exceed the maximum load listed for your vehicle.

**Gross Vehicle Weight Rating:** The maximum allowable weight of the fully loaded vehicle (including passengers and cargo). This number — along with other weight limits, as well as tire, rim size and inflation pressure data — is shown on the vehicle's Safety Compliance Certification Label.

**Payload:** The combined, maximum allowable weight of cargo and passengers that the truck is designed to carry. Payload is GVWR minus the Base Curb Weight.

## NOTATION EXPLANATION

Hazard notations appear in various locations in this publication. Information which is highlighted by one of these notations must be observed to help minimize risk of personal injury or possible improper installation which may render the vehicle unsafe. Notes are used to help emphasize areas of procedural importance and provide helpful suggestions. The following definitions explain the use of these notations as they appear throughout this guide.

### DANGER

INDICATES IMMEDIATE HAZARDS WHICH WILL RESULT IN SEVERE PERSONAL INJURY OR DEATH.

### WARNING

INDICATES HAZARDS OR UNSAFE PRACTICES WHICH COULD RESULT IN SEVERE PERSONAL INJURY OR DEATH.

### CAUTION

INDICATES HAZARDS OR UNSAFE PRACTICES WHICH COULD RESULT IN DAMAGE TO THE MACHINE OR MINOR PERSONAL INJURY.

## NOTE

*Indicates a procedure, practice or hint which is important to highlight.*

# Installation Diagram

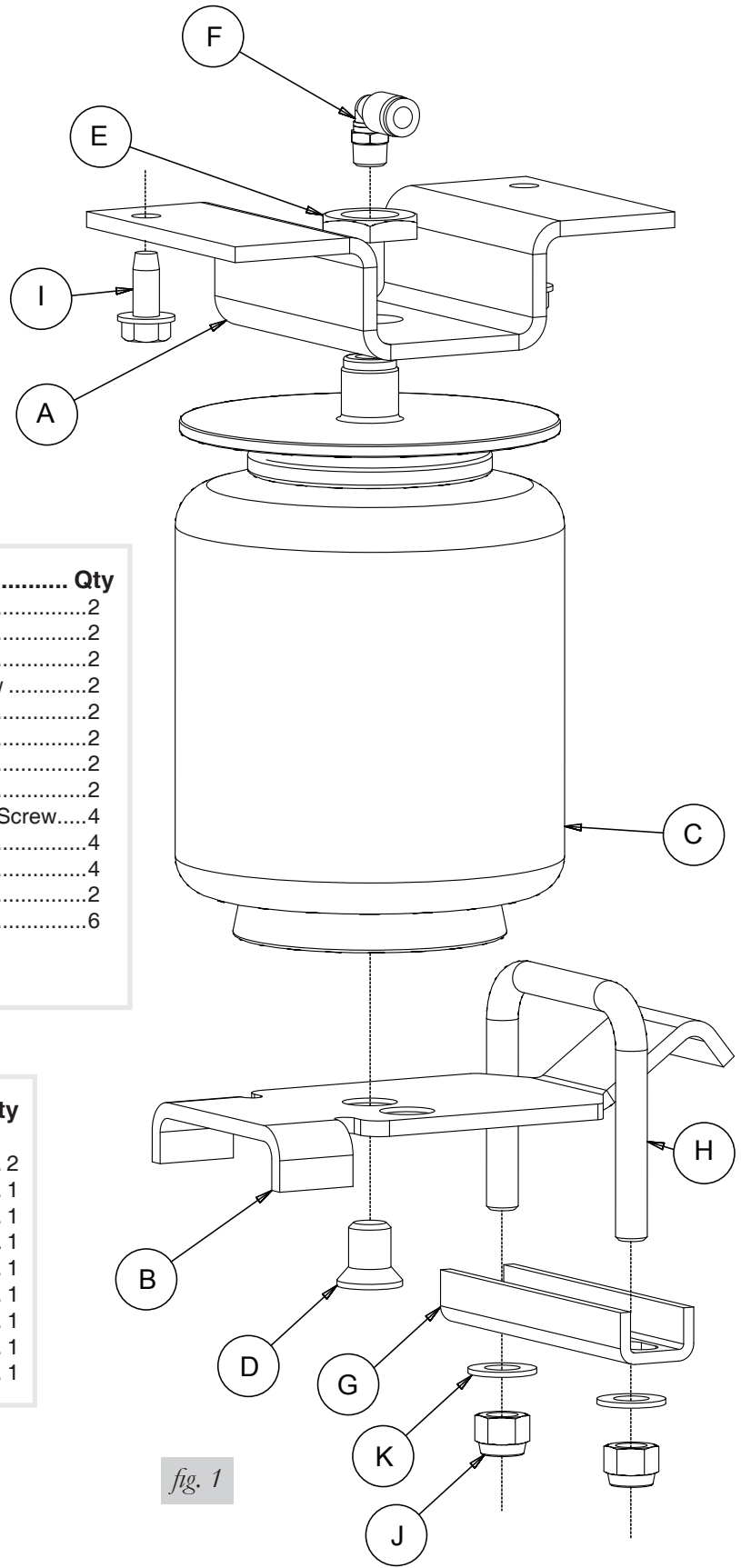

fig. 1

## HARDWARE LIST

Item	Part #	Description .....	Qty
A	07869	Upper Bracket .....	2
B	03437	Lower Bracket .....	2
C	58484	Air Spring .....	2
D	17178	1/2-13 x 3/4 Flat Head Screw .....	2
E	18454	3/4-16 Jam Nut .....	2
F	21848	1/8" Swivel Elbow Fitting .....	2
G	01426	Clamp Bar .....	2
H	10276	U-bolt .....	2
I	17102	5/16-18 x 3/4" Self Tapping Screw .....	4
J	18435	3/8-16 Nyloc Nut .....	4
K	18444	3/8 Flat Washer .....	4
L	20086	Air Line Assembly* .....	2
M	10466	Zip Ties .....	6

\* shown on page 9 (fig. 11)

## TOOLS LIST

Description .....	Qty
Hoist or Floor Jack and Jack Stands	
Safety Stands .....	2
Safety Glasses .....	1
1/4 and 5/16" Drill Bit (very sharp) .....	1
Drill .....	1
Hose Cutter, Razor Blade or Sharp Knife .....	1
Ratchet with 1/2 and 9/16" Sockets .....	1
Medium Size Crescent Wrench .....	1
Air Compressor or Compressed Air source .....	1
Soap Bottle with Dish Soap/Water Solution .....	1



Missing or damaged parts? Call Air Lift customer service at (800) 248-0892 for a replacement part.

# Assembling the Air Spring Assembly

1. Install the swivel elbow air fitting (F) onto the air springs (C) finger tight plus one and a half turns. Do not over tighten.
2. Set the upper bracket (A) over the fitting and the air spring post and cap with a nylon jam nut (E).

## NOTE

*The flat part of the nut will be facing the bracket.*

3. Tighten the nut by holding the nut with a wrench (or medium size crescent wrench) and spinning the air spring by hand (nut only needs to be torqued to 4ft/lbs) (fig. 2).

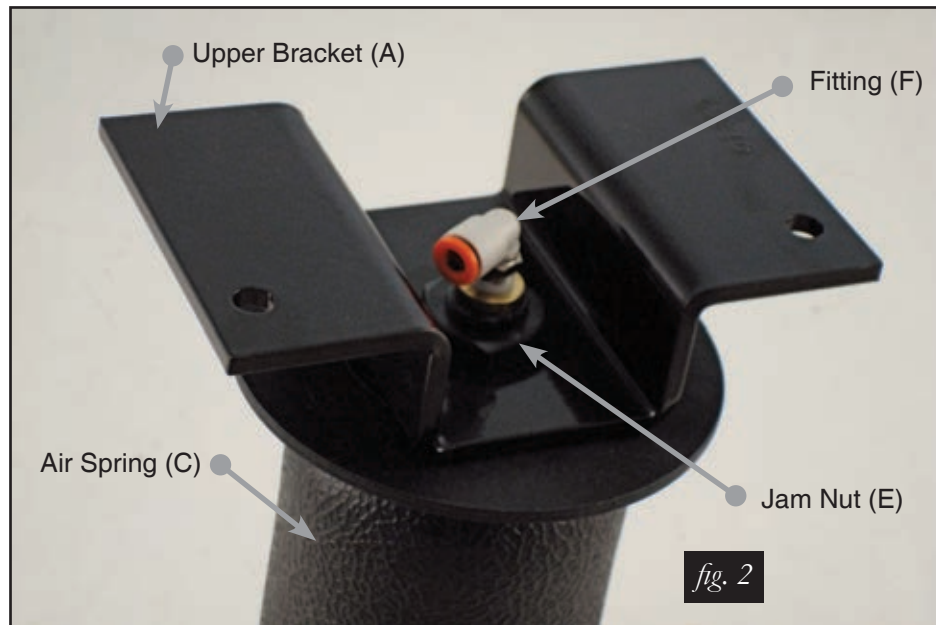

4. Install the lower bracket (B) onto the air spring with the 1/2-13 flat head screw (D) using the middle hole (fig. 3). Leave loose at this time.

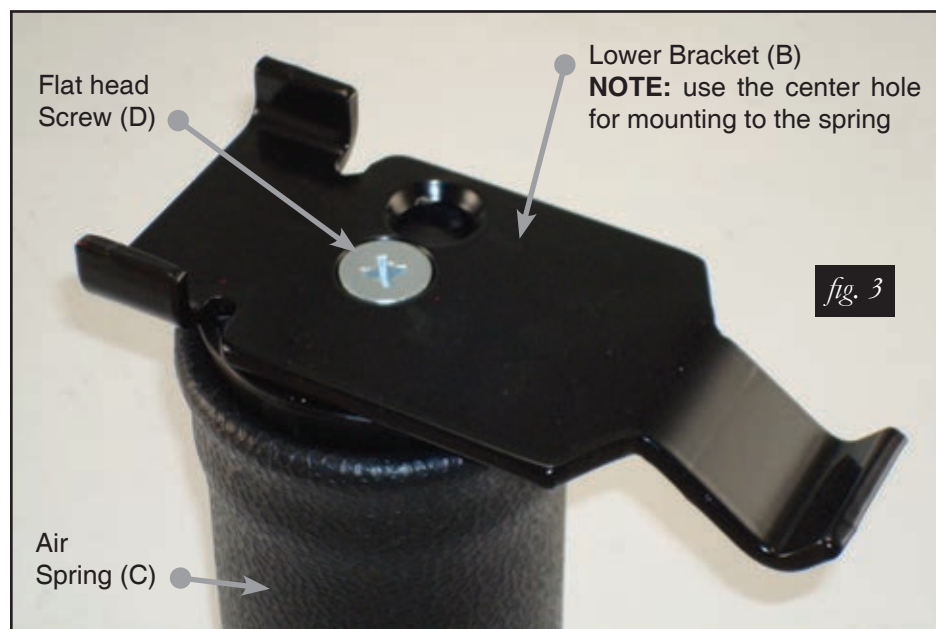

5. The air spring assembly will be installed forward of the axle and there will be a left and a right hand unit when installed, the holes in the upper bracket will be facing inboard towards the center of the vehicle with the “finger” on the lower bracket facing the rear (fig. 4). Once you orient the brackets correctly, align the upper and lower brackets so they are parallel and tighten the flat head screws tight (15 ft/lbs max) (fig. 5).

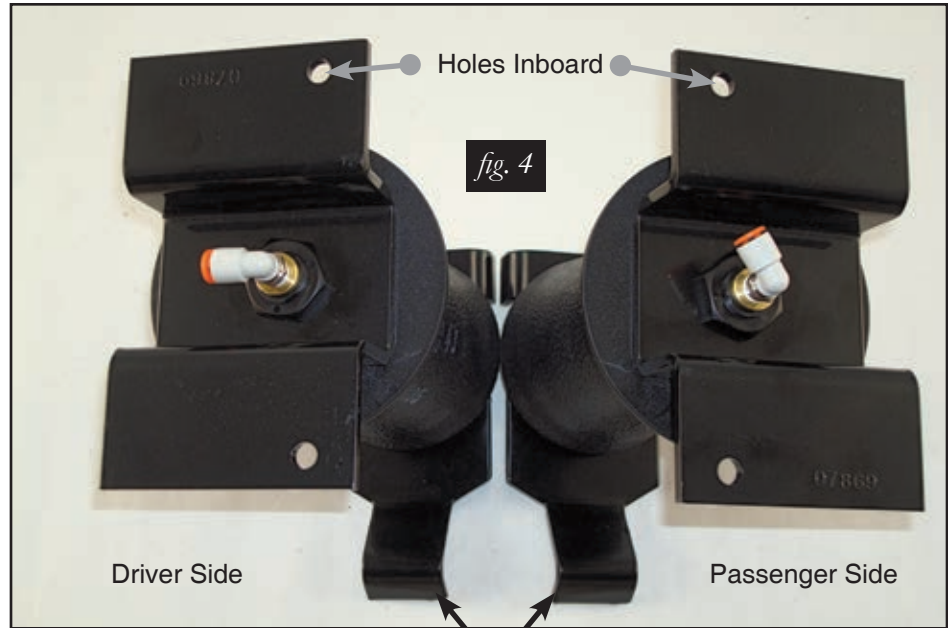

“Fingers” of the lower bracket point to the rear of the vehicle

Upper and lower bracket parallel to each other

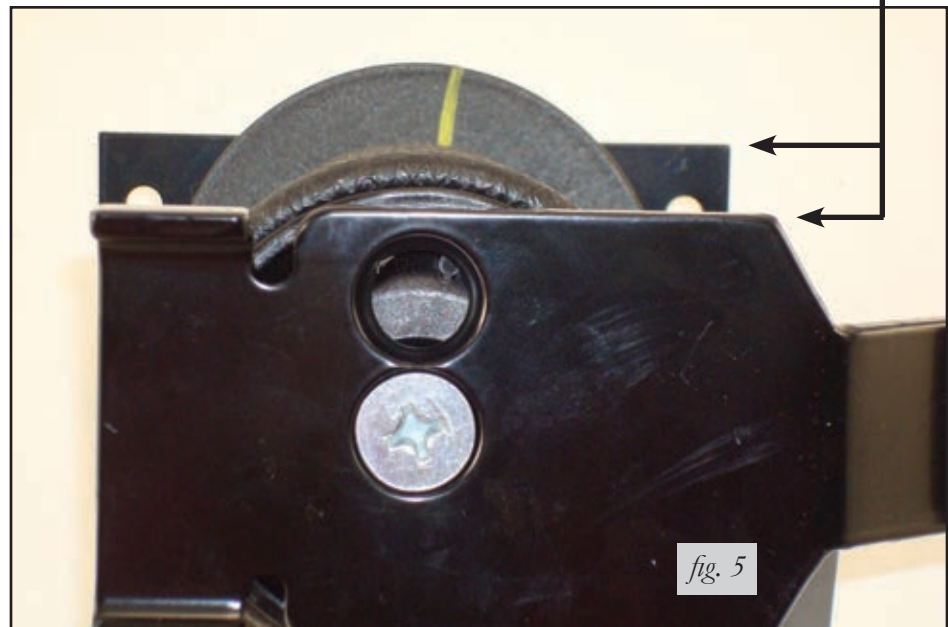

# Installing the RideControl System

## GETTING STARTED

1. Raise the vehicle up with a hoist or jack up the rear with a jack. Place Jack stands under the axle and lower the vehicle down if using a frame contact hoist (so vehicle is at curb height).
2. The air spring assembly fits forward of the axle. On some models there is a thick coat of a body filler type substance that will need to be removed where the upper bracket contacts the frame (fig. 6). Set the left and right hand assembly in place on the axle, make sure the "finger" of the lower bracket is over the leaf spring U-bolt. Align the spring so it is perpendicular to both upper and lower brackets. Mark the frame in the area that the upper bracket makes contact with the frame and remove both assemblies. This is the area that you will need to remove the "body filler" material so that the bracket fits flat to the frame. Use a gasket scraper or a chisel to remove the material.

### NOTE

*I use an air chisel with light pressure to remove the material.*

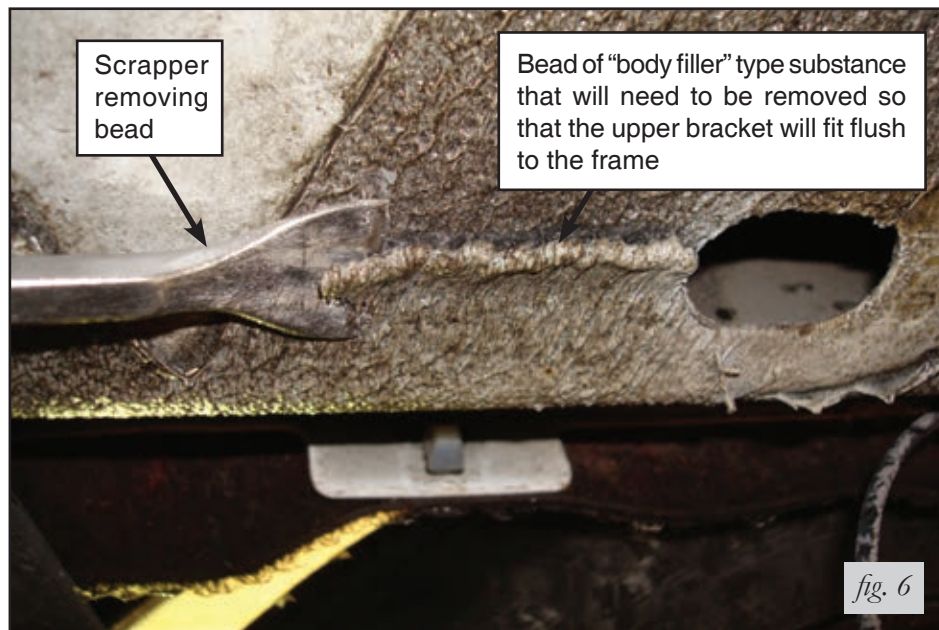

3. Set the assemblies back in place forward of the axle with the holes in the upper bracket pointing inboard.
4. With the finger of the lower bracket over the stock U-bolt, attach it to the leaf spring with the U-bolt (H), clamp bar (G), flat washers (K) and nyloc nuts (J) (fig. 7).

### NOTE

*Offset the lower bracket to the inside of the vehicle on the leaf spring before tightening hardware. Torque to 16ftlbs and repeat for the opposite side.*

5. With the lower bracket attached to the leaf spring, align the upper bracket on the frame so that the air spring is perpendicular to both the upper and lower bracket (fig. 8). Keep the bracket centered on the frame, between the outside and inside while positioning.

### NOTE

*It may be helpful to have slight pressure in the air spring for aligning and attaching the upper bracket to the frame. Cut the air line (L) in two equal lengths (see hose attaching instructions) and insert the air line into the air spring fittings. Inflate the springs to 5psi (or less).*

6. Using the upper bracket as a template, drill two ¼" holes through the bottom of the frame (fig. 8).

Offset the lower bracket inboard on the leaf spring

The "Finger" of the lower bracket must be over the stock U-bolt



fig. 7

Attach the lower bracket with the U-bolt (H), clamp bar (G), flat washers (K) and nyloc nuts (J) provided. Torque hardware to 16 ft/lbs.

You will be drilling on an angle if you do not have an angle drill, this will be ok, just try to start the self-tapping screw straight when tightening it.

The frame above the forward holes have a double wall to them and you will have to drill through both to attach the upper bracket with the self-tapping screw (I) provided.



fig. 8

**NOTE:** Driver (left) side shown

**NOTE**

Unless you have an angle drill, you will be drilling the holes on an angle because of the leaf spring interference. This will be ok and should not be a problem with attaching the self tapping screws provided. Also, the forward holes have a double wall, be sure to drill all the way through both in order for the self tapping screw to tighten correctly.

7. Attach the upper bracket using the self tapping screws (l) (fig. 9). Snug the bolts only, do not over tighten them. Repeat for the opposite side.

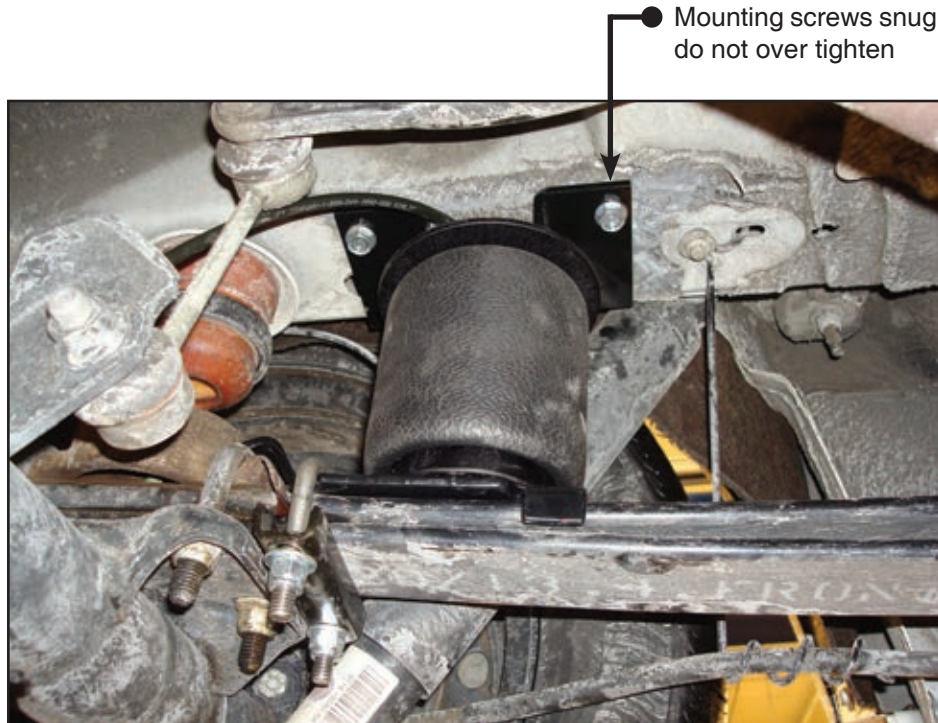

fig. 9

## INSTALLING THE AIR LINES

1. Choose a convenient location for mounting the inflation valves. Popular locations for the inflation valve are:
  - a. The wheel well flanges
  - b. The license plate recess in bumper
  - c. Under the gas cap access door
  - d. Through the license plate

**NOTE**

Whatever the chosen location, make sure there is enough clearance around the inflation valves for an air chuck.

2. Drill two 5/16" holes to install the inflation valves.
3. Cut the air line assembly in two equal lengths.

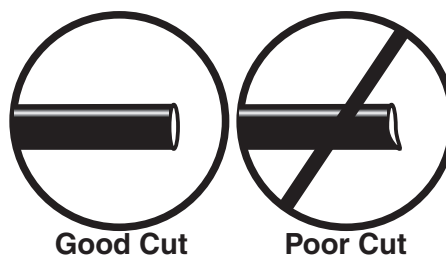
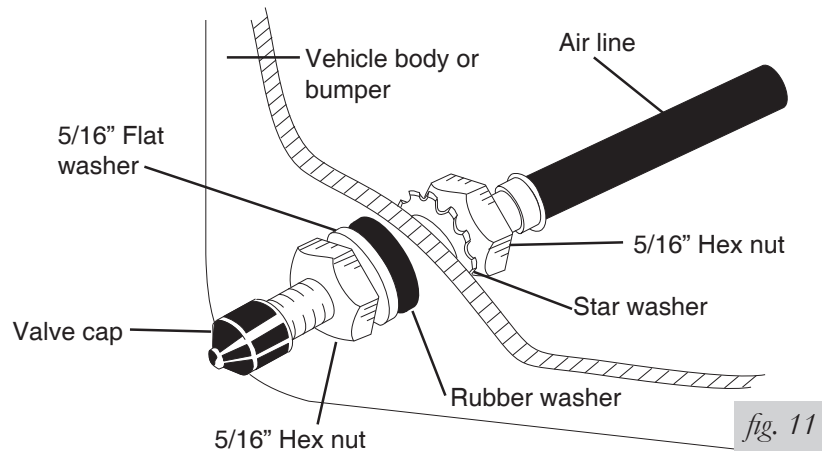

fig. 10

 **CAUTION**

WHEN CUTTING OR TRIMMING THE AIR LINE, USE A HOSE CUTTER, A RAZOR BLADE, OR A SHARP KNIFE. A CLEAN, SQUARE CUT WILL ENSURE AGAINST LEAKS. DO NOT USE WIRE CUTTERS OR SCISSORS TO CUT THE AIR LINE. THESE TOOLS MAY FLATTEN OR CRIMP THE AIR LINE CAUSING IT TO LEAK AROUND THE O-RING SEAL INSIDE THE ELBOW FITTING (FIG. 10).



4. Place a 5/16" nut and star washer on the air valve. Leave enough of the inflation valve in front of the nut to extend through the hole and have room for the rubber washer, flat washer, and 5/16" nut and cap. There should be enough valve exposed after installation—approximately 1/2"—to easily apply a pressure gauge or an air chuck (fig. 11).
5. Push the inflation valve through the hole and use the rubber washer, flat washer, and another 5/16" nut to secure it in place. Tighten the nuts to secure the assembly.
6. Route the air line along the frame to the air fitting on the air spring (fig. 12). Keep AT LEAST 6" of clearance between the air line and heat sources, such as the exhaust pipes, muffler, or catalytic converter. Avoid sharp bends and edges. Use the plastic tie straps to secure the air line to fixed, non-moving points along the chassis. Be sure that the tie straps are tight, but do not pinch the air line. Leave at least 2" of slack to allow for any movement that might pull on the air line (fig. 12).

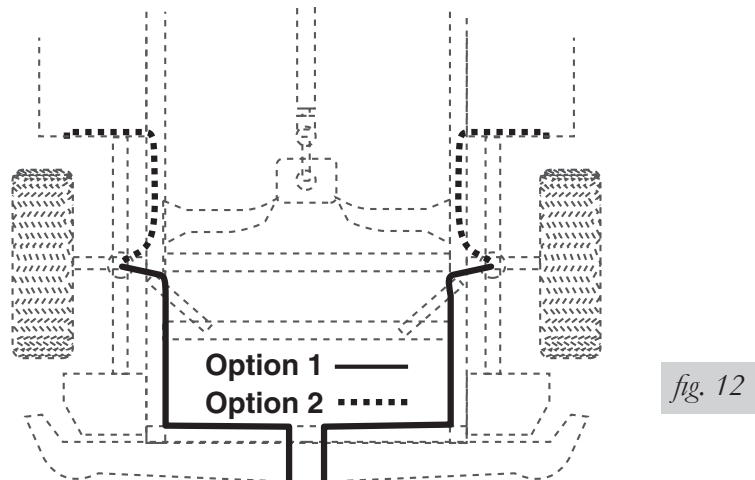

7. Cut off the air line, leaving approximately 12" of extra air line. A clean square cut will ensure against leaks. Insert the air line into the air fitting. This is a push-to-connect fitting. Simply push the air line into the 90° swivel fitting until it bottoms out (9/16" of air line should be in the fitting).
8. Install the minimum/maximum air pressure decal in a highly visible location. We suggest placing the decal on the driver-side window, just above the door handle.

## CHECKING FOR LEAKS

1. Inflate the air spring to 30 PSI.
2. Spray all connections and the inflation valves with a solution of 1/5 liquid dish soap and 4/5 water. Spot leaks easily by looking for bubbles in the soapy water.
3. After the test, deflate the springs to the minimum pressure required to restore the system to normal ride height. Do not deflate to lower than 5 PSI.
4. Check the air pressure again after 24 hours. A 2 - 4 PSI loss after initial installation is normal. Retest for leaks if the loss is more than 5 lbs.

## FIXING LEAKS

1. If there is a problem with the swivel fitting:
  - a. Check the air line connection by deflating the spring and removing the line by pulling the collar against the fitting and pulling firmly on the air line. Trim 1" off the end of the air line. Be sure the cut is clean and square (see fig. 10). Reinsert the air line into the push-to-connect fitting.
  - b. Check the threaded connection by tightening the swivel fitting another ½ turn. If it still leaks, deflate the air spring, remove the fitting, and re-coat the threads with thread sealant. Reinstall by hand tightening as much as possible and then use a wrench for an additional two turns.
2. If there is a problem with the inflation valve:
  - a. Check the valve core by tightening it with a valve core tool.
  - b. Check the air line by removing the air line from the barbed type fitting. Cut the air line off a few inches in front of the fitting and use a pair of pliers or vice grips to pull/twist the air line off of the fitting.

 **CAUTION**

DO NOT CUT OFF THE AIR LINE COMPLETELY AS THIS WILL USUALLY NICK THE BARB AND RENDER THE FITTING USELESS.

3. If the preceding steps have not resolved the problem, call Air Lift customer service at (800) 248-0892.

# Before Operating

## INSTALLATION CHECKLIST

- Clearance test — Inflate the air springs to 30 PSI and ensure there is at least ½” clearance around each sleeve, away from anything that might rub against them. Be sure to check the tire, brake drum, frame, shock absorbers and brake cables.
- Leak test before road test — Inflate the air springs to 30 PSI, check all connections for leaks with a soapy water solution. See page 10 for tips on how to spot leaks. All leaks must be eliminated before the vehicle is road tested.
- Heat test — Be sure there is sufficient clearance from any heat sources — at least 6” for air springs and air lines. If a heat shield was included in the kit, install it. If there is no heat shield, but one is required, call (800) 248-0892.
- Fastener test — Recheck all bolts for proper torque. Axle straps carriage bolt lock nuts should be torqued to 16 ft/lbs. Re-torque after 100 miles.
- Road test — The vehicle should be road tested after the preceding tests. Inflate the air springs to 25 PSI (50 PSI if the vehicle is loaded). Drive the vehicle 10 miles and recheck for clearance, loose fasteners and air leaks.
- Operating instructions — If professionally installed, the installer should review the operating instructions with the owner. Be sure to provide the owner with all of the paperwork which came with the kit.

**Technician's Signature** \_\_\_\_\_

**Date** \_\_\_\_\_

## POST-INSTALLATION CHECKLIST

- Overnight leak down test — Recheck air pressure after the vehicle has been used for 24 hours. If the pressure has dropped more than 5 PSI, then there is a leak that must be fixed. Either fix the leak yourself or return to the installer for service.
- Air pressure requirements — I understand the air pressure requirements of my air spring system. Regardless of load, the air pressure should always be adjusted to maintain ride height at all times.
- Thirty day or 500 mile test — I understand that I must recheck the air spring system after 30 days or 500 miles, whichever comes first. If any part shows signs of rubbing or abrasion, the source should be identified and moved, if possible. If it is not possible to relocate the cause of the abrasion, the air spring may need to be remounted. If professionally installed, the installer should be consulted. Check all fasteners for tightness.

# Product Use, Maintenance and Servicing

Minimum Air Pressure	Maximum Air Pressure
10 PSI	100 PSI
FAILURE TO MAINTAIN CORRECT MINIMUM PRESSURE (OR PRESSURE PROPORTIONAL TO LOAD), BOTTOMING OUT, OVER-EXTENSION OR RUBBING AGAINST ANOTHER COMPONENT WILL VOID THE WARRANTY.	

## MAINTENANCE GUIDELINES

### NOTE

*By following the steps below, vehicle owners will obtain the longest life and best results from their air springs.*

1. Check the air pressure weekly.
2. Always maintain normal ride height. Never inflate beyond 100 PSI.
3. If you develop an air leak in the system, use a soapy water solution (1/5 liquid dish soap and 4/5 water) to check all air line connections and the inflation valve core before deflating and removing the air spring.

### CAUTION

FOR YOUR SAFETY AND TO PREVENT POSSIBLE DAMAGE TO YOUR VEHICLE, DO NOT EXCEED MAXIMUM GROSS VEHICLE WEIGHT RATING (GVWR), AS INDICATED BY THE VEHICLE MANUFACTURER. ALTHOUGH YOUR AIR SPRINGS ARE RATED AT A MAXIMUM INFLATION PRESSURE OF 100 P.S.I., THE AIR PRESSURE ACTUALLY NEEDED IS DEPENDENT ON YOUR LOAD AND GVWR.

4. Loaded vehicles require at least 25 PSI or more. A “loaded vehicle” refers to a vehicle with a heavy bed load, a trailer, or both. As discussed above, never exceed GVWR, regardless of air spring, air pressure, or other load assist. The springs in this kit will support approximately 40 lbs. of load (combined on both springs) for each 1 PSI of pressure. The required air pressure will vary depending on the state of the original suspension. Operating the vehicle below the minimum air spring pressure will void the Air Lift warranty.
5. When increasing load, always adjust the air pressure to maintain the normal ride height. Increase or decrease pressure from the system as necessary to attain normal ride height for optimal ride and handling. Remember that loads carried behind the axle (including tongue loads) require more leveling force (pressure) than those carried directly over the axle.
6. Always add air to springs in small quantities, checking the pressure frequently.
7. Should it become necessary to raise the vehicle by the frame, make sure the system is at minimum pressure (5 PSI) to reduce the tension on the suspension/brake components. Use of on board leveling systems do not require deflation or disconnection.
8. Periodically check the air spring system fasteners for tightness. Also, check the air springs for any signs of rubbing. Realign if necessary.
9. On occasion, give the air springs a hard spray with a garden hose in order to remove mud, sand, gravel or other abrasive debris.

## TROUBLESHOOTING GUIDE

1. Leak test the air line connections, the threaded connection into the air spring, and all fittings in the control system.
2. Inspect the air lines to be sure none are pinched. Tie straps may be too tight. Loosen or replace the strap and replace leaking components.
3. Inspect the air line for holes and cracks. Replace as needed.
4. Look for a kink or fold in the air line. Reroute as needed.

If the preceding steps do not solve the problem, it is possibly caused by a failed air spring — either a factory defect or an operating problem. Please call Air Lift at (800) 248-0892 for assistance.

## FREQUENTLY ASKED QUESTIONS

### **Q. Will installing air springs increase the weight ratings of a vehicle?**

No. Adding air springs will not change the weight ratings (GAWR, GCWR and/or GVWR) of a vehicle. Exceeding the GVWR is dangerous and voids the Air Lift warranty.

**Q. Is it necessary to keep air in the air springs at all times and how much pressure will they need?**

The minimum air pressure should be maintained at all times. The minimum air pressure keeps the air spring in shape, ensuring that it will move throughout its travel without rubbing or wearing on itself.

**Q. Is it necessary to add a compressor system to the air springs?**

No. Air pressure can be adjusted with any type of compressor as long as it can produce sufficient pressure to service the springs. Even a bicycle tire pump can be used, but it's a lot of work.

**Q. How long should air springs last?**

If the air springs are properly installed and maintained they can last indefinitely.

**Q. Will raising the vehicle on a hoist for service work damage the air springs?**

No. The vehicle can be lifted on a hoist for short-term service work such as tire rotation or oil changes. However, if the vehicle will be on the hoist for a prolonged period of time, support the axle with jack stands in order to take the tension off of the air springs.

## TUNING THE AIR PRESURE

Pressure determination comes down to three things — level vehicle, ride comfort, and stability.

### 1. Level vehicle

If the vehicle's headlights are shining into the trees or the vehicle is leaning to one side, then it is not level (fig. 13). Raise the air pressure to correct either of these problems and level the vehicle.

### 2. Ride comfort

If the vehicle has a rough or harsh ride it may be due to either too much pressure or not enough (fig. 14). Try different pressures to determine the best ride comfort.

### 3. Stability

Stability translates into safety and should be the priority, meaning the driver may need to sacrifice a perfectly level and comfortable ride. Stability issues include roll control, bounce, dive during braking and sponginess (fig. 15). Tuning out these problems usually requires an increase in pressure.



## GUIDELINES FOR ADDING AIR

1. Start with the vehicle level or slightly above.
2. When in doubt, always add air.
3. For motorhomes, start with 50-100 PSI in the rear because it can be safely assumed that it is heavily loaded.
4. If the front of the vehicle dives while braking, increase the pressure in the front air bags, if equipped.

5. If it is ever suspected that the air bags have bottomed out, increase the pressure (fig. 16).
6. Adjust the pressure up and down to find the best ride.
7. If the vehicle rocks and rolls, adjust the air pressure to reduce movement.
8. It may be necessary to maintain different pressures on each side of the vehicle. Loads

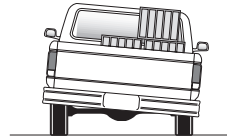

Bottoming out

*fig. 16*

Unlevel

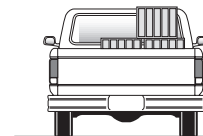

Level

*fig. 17*

## Warranty and Returns Policy

Air Lift Company warrants its products, for the time periods listed below, to the original retail purchaser against manufacturing defects when used on catalog-listed applications on cars, vans, light trucks and motorhomes under normal operating conditions for as long as Air Lift manufactures the product. The warranty does not apply to products that have been improperly applied, improperly installed, used in racing or off-road applications, used for commercial purposes, or which have not been maintained in accordance with installation instructions furnished with all products. The consumer will be responsible for removing (labor charges) the defective product from the vehicle and returning it, transportation costs prepaid, to the dealer from which it was purchased or to Air Lift Company for verification.

Air Lift will repair or replace, at its option, defective products or components. A minimum \$10.00 shipping and handling charge will apply to all warranty claims. Before returning any defective product, you must call Air Lift at (800) 248-0892 in the U.S. and Canada (elsewhere, (517) 322-2144) for a Returned Materials Authorization (RMA) number. Returns to Air Lift can be sent to: Air Lift Company • 2727 Snow Road • Lansing, MI • 48917.

Product failures resulting from abnormal use or misuse are excluded from this warranty. The loss of use of the product, loss of time, inconvenience, commercial loss or consequential damages is not covered. The consumer is responsible for installation/reinstallation (labor charges) of the product. Air Lift Company reserves the right to change the design of any product without assuming any obligation to modify any product previously manufactured.

This warranty gives you specific legal rights and you may also have other rights that vary from state-to-state. Some states do not allow limitations on how long an implied warranty lasts or allow the exclusion or limitation of incidental or consequential damages. The above limitation or exclusion may not apply to you. There are no warranties, expressed or implied including any implied warranties of merchantability and fitness, which extend beyond this warranty period. There are no warranties that extend beyond the description on the face hereof. Seller disclaims the implied warranty of merchantability. (Dated proof of purchase required.)

<b>Air Lift 1000</b> .....	<b>Lifetime Limited</b>	<b>LoadController/Dual</b> .....	<b>2 Year Limited</b>
<b>RideControl</b> .....	<b>Lifetime Limited</b>	<b>Load Controller (I)</b> .....	<b>2 Year Limited</b>
<b>LoadLifter 5000*</b> .....	<b>Lifetime Limited</b>	<b>Load Controller (II)</b> .....	<b>2 Year Limited</b>
<b>SlamAir</b> .....	<b>Lifetime Limited</b>	<b>SmartAir</b> .....	<b>2 Year Limited</b>
<b>AirCell</b> .....	<b>Lifetime Limited</b>	<b>Wireless AIR</b> .....	<b>2 Year Limited</b>
<b>Lifestyle &amp; Performance**</b> ....	<b>1 Year Limited</b>	<b>WirelessONE</b> .....	<b>2 Year Limited</b>
<b>LoadController/Single</b> .....	<b>2 Year Limited</b>	<b>Other Accessories</b> .....	<b>2 Year Limited</b>

*\*formerly SuperDuty*

*\*\*formerly EasyStreet*

# Replacement Parts and Returns



## Please do not cannibalize kits for parts!

*Help us avoid waste and order by part number. If you need an air spring replacement part, please follow these steps.*

**Step 1** Contact your dealer and order by part number. Download a detailed list at [www.airliftcompany.com/downloads.html](http://www.airliftcompany.com/downloads.html).

**Step 2** If your dealer does not have the part in stock, call Air Lift directly and we can ship you the part you need, the same day, in the U.S. or Canada.

### Missing or damaged item?

Before calling Air Lift customer service, please gather the following information:

- Your receipt
- Condition the kit was in when you purchased it
- Description or part number of the missing/damaged item
- Information from the box label
  1. Kit number
  2. Weight
  3. When was the kit packed?

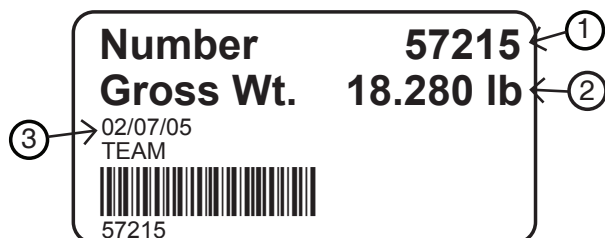

## Replacement Information

If you need replacement parts, contact the local dealer or call Air Lift customer service at (800) 248-0892. Most parts are immediately available and can be shipped the same day.

### Contact Air Lift Company customer service at (800) 248-0892 first if:

- Parts are missing from the kit.
- Need technical assistance on installation or operation.
- Broken or defective parts in the kit.
- Wrong parts in the kit.
- Have a warranty claim or question.

### Contact the retailer where the kit was purchased:

- If it is necessary to return or exchange the kit for any reason.
- If there is a problem with shipping if shipped from the retailer.
- If there is a problem with the price.



# Thank you for purchasing Air Lift products!

We're delighted to be a part of your air suspension solution. Air Lift Company is dedicated to ensuring that you have the best possible experience with our products. If you have any questions, concerns or even a suggestion, please feel free to contact us.

## It's easy to put your air springs to work with an Air Lift on board air compressor system!

Air Lift offers the most advanced compressor systems in the industry. Choose the best option for your ride from many models and features!



WirelessAIR  
#72000

WirelessONE  
#25870

\*Four air springs require TWO compressor systems.

Choose the system best suited for your...	Analog Series		Wireless Series		Automatic Leveling
	Standard Duty	Heavy Duty	Single/Standard Duty	Dual/Heavy Duty	Automatic Leveling
<i>Pick-up with any towable</i>	25850*	25854**	25870	72000	25415
<i>Pick-up with camper</i>	25852***	25856****	N/R	72000	25430
<i>Van/SUV with leaf springs</i>	25850*	25854**	25870	72000	25415
<i>Vehicle with coil springs</i>	25850*	25854**	25870	72000	N/R
<i>Motor home</i>	N/R	25856****	N/R	72000	25430
<i>Unique applications</i>	call	call	call	call	call



LoadController/Single  
#s 25850 & 25854



LoadController/Dual  
#s 25852 & 25856

Still available in panel mount style: \*25592, \*\* 25655, \*\*\*25812, \*\*\*\*25651

N/R = Not Recommended

**Save time and money! Register your warranty online today at  
[www.airliftcompany.com/warrantyreg.htm](http://www.airliftcompany.com/warrantyreg.htm)**

## Contact Information

If you have any questions, comments or need technical assistance contact our customer service department by calling (800) 248-0892, Monday through Friday, 8 a.m. to 7 p.m. Eastern Time. For calls from outside the USA or Canada, our local number is (517) 322-2144.

For inquiries by mail, our address is PO Box 80167, Lansing, MI 48908-0167. Our shipping address for returns is 2727 Snow Road, Lansing, MI 48917.

You may also contact us anytime by e-mail at [sales@airliftcompany.com](mailto:sales@airliftcompany.com) or on the web at [www.airliftcompany.com](http://www.airliftcompany.com).



## Need Help?

Contact our customer service department by calling (800) 248-0892, Monday through Friday, 8 a.m. to 7 p.m. Eastern Time. For calls from outside the USA or Canada, our local number is (517) 322-2144.

**Register your warranty online at  
[www.airliftcompany.com/warranty](http://www.airliftcompany.com/warranty)**



*Thank you for purchasing Air Lift products — the professional installer's choice!*

Air Lift Company • 2727 Snow Road • Lansing, MI 48917 or PO Box 80167 • Lansing, MI 48908-0167  
Toll Free (800) 248-0892 • Local (517) 322-2144 • Fax (517) 322-0240 • [www.airliftcompany.com](http://www.airliftcompany.com)

Printed in  
the USA